

| LSJ-27-PR TECHNICAL CHARACTERISTICS | |
|--|---|
| PAYLOAD | 270 daN |
| NET WEIGHT | 160 Kg |
| SERVICE LOAD | 350 daN |
| SPEED | 7 mt/min |
| TYPE OF SPEED | FIXED VARIABLE (OPTIONAL) |
| MAX TRAVEL | UP TO 12 meters |
| ROPES | 4 |
| ROPE DIAMETER | 4 mm |
| ROPE TYPE | LANG LAY GALVANIZED MBL 10,5 KN |
| LOAD POLE POSITIONING ERROR | Ø48,3-50 mm - L 1700-3000 mm ± 0,05 % |
| EXAMPLE FOR OUTLETS | 16 A CEE / 32 A CEE 16 A SHUKO / DMX |
| MOTOR POWER | 0,75 KW |
| BRAKE TYPE | DOUBLE ELECTROMAGNETIC MOUNTED ON MOTOR |
| REDUCER GEARBOX | COAXIAL |
| LIMIT SWITCH | ROTARY 4 SWITCHES |
| ENCODER | ABSOLUTE (OPTIONAL) ON OUTPUT SHAFT |
| LOAD CELL | OPTIONAL |
| AUXILIARY SAFETIES | CABLE-BREAK ON BOARD SLACK CABLE DETECTORS ON EACH SUPPORTING CABLES(OPTIONAL) |
| <small>IN ACCORDANCE TO THE EUROPEAN MACHINERY DIRECTIVE, TO DIN 56950 BGV D8+ REGULATIONS * AND WITH CE MARKING . * IF OPTIONALS ARE FULL SELECTED THE MACHINE BECOMES BGV C1 .</small> | |

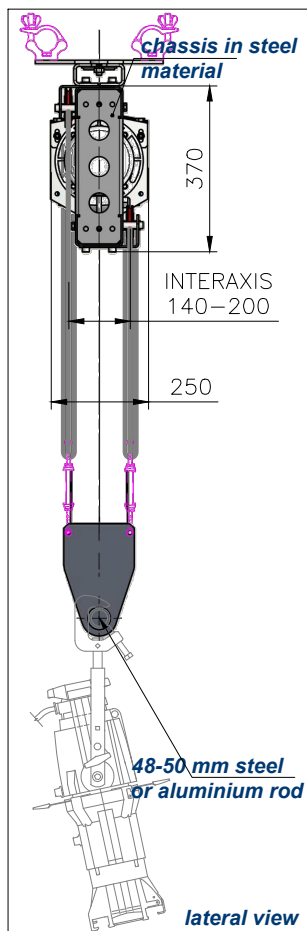

| LSJ-37-PR TECHNICAL CHARACTERISTICS | |
|--|---|
| PAYLOAD | 370 daN |
| NET WEIGHT | 180 Kg |
| SERVICE LOAD | 510 daN |
| SPEED | 8 mt/min |
| TYPE OF SPEED | FIXED VARIABLE (OPTIONAL) |
| MAX TRAVEL | UP TO 15 meters |
| ROPES | 4 |
| ROPE DIAMETER | 5 mm |
| ROPE TYPE | LANG LAY GALVANIZED MBL 17,7 KN |
| LOAD POLE POSITIONING ERROR | Ø48,3-50 mm - L 1700-3000 mm ± 0,05 % |
| EXAMPLE FOR OUTLETS | 16 A CEE / 32 A CEE 16 A SHUKO / DMX |
| MOTOR POWER | 1,1 KW |
| BRAKE TYPE | DOUBLE ELECTROMAGNETIC MOUNTED ON MOTOR |
| REDUCER GEARBOX | COAXIAL |
| LIMIT SWITCH | ROTARY 4 SWITCHES |
| ENCODER | ABSOLUTE (OPTIONAL) ON OUTPUT SHAFT |
| LOAD CELL | OPTIONAL |
| AUXILIARY SAFETIES | CABLE-BREAK ON BOARD SLACK CABLE DETECTORS ON EACH SUPPORTING CABLES(OPTIONAL) |
| <small>IN ACCORDANCE TO THE EUROPEAN MACHINERY DIRECTIVE, TO DIN 56950 BGV D8+ REGULATIONS * AND WITH CE MARKING . * IF OPTIONALS ARE FULL SELECTED THE MACHINE BECOMES BGV C1 .</small> | |

DECIMA
1948

| | | | |
|--------|------------|--------|---------------------|
| DATE | 2016/11/24 | WEIGHT | |
| DRAWER | M.Z. | SCALE | |
| VERIF. | M.Z. | SHEET | A4 |
| REV. | 5 | CODE | LSJ-27-PR LSJ-37-PR |

DESCR. - PARALLEL ROPES HOISTS - LSJ TYPES