

LSJ15-SC TECHNICAL CHARACTERISTICS	
PAYLOAD	150 daN
NET WEIGHT	220 Kg
RATED CAPACITY	370 daN
SPEED	6,5-10 mt/min
TYPE OF SPEED	FIXED OR VARIABLE
MAX TRAVEL	UP TO 12 meters
ROPES	4 LANG LAY GALVANIZED MBL 10,5 KN
ROPE DIAMETER	4 mm
SELF CLIMBING TYPE	SINGLE / DOUBLE PURCHASED SYSTEM
LOAD POLE	Ø48,3-50 mm - L 2100-5000 mm
POSITIONING ERROR	± 0,05 %
EXAMPLE FOR OUTLETS	16 A CEE / 32 A CEE 16 A SHUKO / DMX
MOTOR POWER	0,75-1,1 KW
BRAKE TYPE	DOUBLE ELECTROMAGNETIC MOUNTED ON MOTOR
REDUCER GEARBOX	COAXIAL
LIMIT SWITCH	ROTARY 4 SWITCHES
ENCODER	ABSOLUTE (OPTIONAL) ON OUTPUT SHAFT
LOAD CELL	OPTIONAL
AUXILIARY SAFETIES	WIRE CABLE PRESSING ROLLERS SLACK CABLE DETECTORS ON EACH SUPPORTING CABLES(OPTIONAL)
IN ACCORDANCE TO THE EUROPEAN MACHINERY DIRECTIVE, TO DIN 56950 BGV D8+ REGULATIONS AND WITH CE MARKING .	

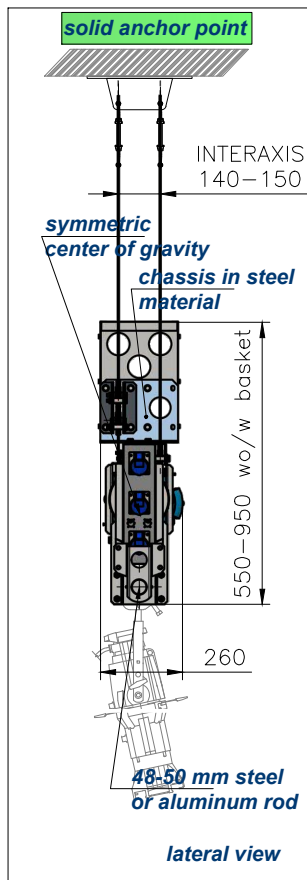

LSJ30-SC TECHNICAL CHARACTERISTICS	
PAYLOAD	300 daN
NET WEIGHT	250 Kg
RATED CAPACITY	550 daN
SPEED	6,5*-11 mt/min
TYPE OF SPEED	FIXED OR VARIABLE, *6,5 mt/min ONLY WITH 250 daN MAX PAYLOAD
MAX TRAVEL	UP TO 15 meters
ROPES	4 LANG LAY GALVANIZED MBL 17,7 KN
ROPE DIAMETER	5 mm
SELF CLIMBING TYPE	SINGLE / DOUBLE PURCHASED SYSTEM
LOAD POLE	Ø48,3-50 mm - L 2500-6000 mm
POSITIONING ERROR	± 0,05 %
EXAMPLE FOR OUTLETS	16 A CEE / 32 A CEE 16 A SHUKO / DMX
MOTOR POWER	1,1-1,5 KW
BRAKE TYPE	DOUBLE ELECTROMAGNETIC MOUNTED ON MOTOR
REDUCER GEARBOX	COAXIAL
LIMIT SWITCH	ROTARY 4 SWITCHES
ENCODER	ABSOLUTE (OPTIONAL) ON OUTPUT SHAFT
LOAD CELL	OPTIONAL
AUXILIARY SAFETIES	WIRE CABLE PRESSING ROLLERS SLACK CABLE DETECTORS ON EACH SUPPORTING CABLES(OPTIONAL)
IN ACCORDANCE TO THE EUROPEAN MACHINERY DIRECTIVE, TO DIN 56950 BGV D8+ REGULATIONS AND WITH CE MARKING .	



DESCR. - SELF CLIMBING HOISTS - LSJ TYPES

DATE	2020/06/13	WEIGHT	220 - 250 Kg
DRAWER	M.Z.	SCALE	
VERIF.	M.Z.	SHEET	A4
REV.	10	CODE	LSJ15-SC LSJ30-SC