

LSJ27-AR TECHNICAL CHARACTERISTICS	
PAYLOAD	270 daN
NET WEIGHT	240 Kg
RATED CAPACITY	380 daN
SPEED	7 mt/min
TYPE OF SPEED	FIXED VARIABLE (OPTIONAL)
MAX TRAVEL	UP TO 12 meters
ROPES	4
ROPE DIAMETER	4 mm
ROPE TYPE	LANG LAY GALVANIZED MBL 10,5 KN
LOAD POLE	Ø48,3-50 mm - L 1700-12000 mm
POSITIONING ERROR	± 0,05 %
EXAMPLE FOR OUTLETS	16 A CEE / 32 A CEE 16 A SHUKO / DMX
MOTOR POWER	0,75 KW
BRAKE TYPE	DOUBLE ELECTROMAGNETIC MOUNTED ON MOTOR
REDUCER GEARBOX	COAXIAL
LIMIT SWITCH	ROTARY 4 SWITCHES
ENCODER	ABSOLUTE (OPTIONAL) ON OUTPUT SHAFT
LOAD CELL	OPTIONAL
AUXILIARY SAFETIES	SLACK CABLE DETECTORS ON EACH SUPPORTING CABLES, CABLE-BREAK ON BOARD (OPTIONAL)
IN ACCORDANCE TO THE EUROPEAN MACHINERY DIRECTIVE, TO DIN 56950 BGV D8+ REGULATIONS AND WITH CE MARKING .	

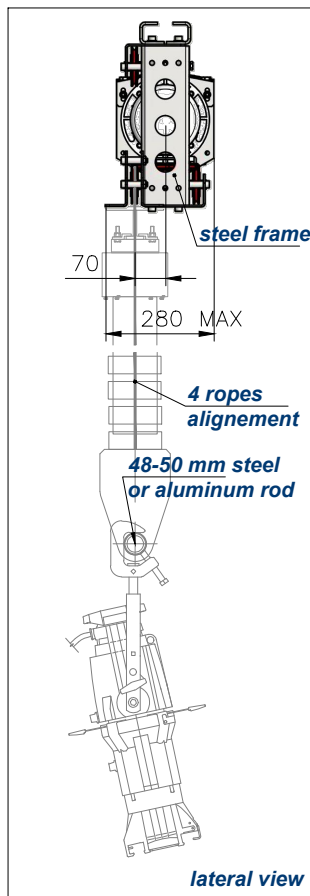

LSJ37-AR TECHNICAL CHARACTERISTICS	
PAYLOAD	370 daN
NET WEIGHT	290 Kg
RATED CAPACITY	480 daN
SPEED	8 mt/min
TYPE OF SPEED	FIXED VARIABLE (OPTIONAL)
MAX TRAVEL	UP TO 15 meters
ROPES	4
ROPE DIAMETER	5 mm
ROPE TYPE	LANG LAY GALVANIZED MBL 17,7 KN
LOAD POLE	Ø48,3-50 mm - L 1700-12000 mm
POSITIONING ERROR	± 0,05 %
EXAMPLE FOR OUTLETS	16 A CEE / 32 A CEE 16 A SHUKO / DMX
MOTOR POWER	1,1 KW
BRAKE TYPE	DOUBLE ELECTROMAGNETIC MOUNTED ON MOTOR
REDUCER GEARBOX	COAXIAL
LIMIT SWITCH	ROTARY 4 SWITCHES
ENCODER	ABSOLUTE (OPTIONAL) ON OUTPUT SHAFT
LOAD CELL	OPTIONAL
AUXILIARY SAFETIES	SLACK CABLE DETECTORS ON EACH SUPPORTING CABLES, CABLE-BREAK ON BOARD (OPTIONAL)
IN ACCORDANCE TO THE EUROPEAN MACHINERY DIRECTIVE, TO DIN 56950 BGV D8+ REGULATIONS AND WITH CE MARKING .	



DATE _{y/m/d}	2019/04/17	WEIGHT	240 - 290 Kg
DRAWER	M.Z.	SCALE	-
VERIF.	M.Z.	SHEET	A4
REV.	8	CODE	LSJ27-AR LSJ37-AR

DESCR. - ALIGNED ROPES HOISTS - LSJ TYPES